

Optical Transmitter

RF-T860/24

Installation & Operation Manual



Caution

These servicing instructions are for use by qualified personnel only. To reduce the risk of electrical shock, please do not perform any servicing other than that contained in the installation manual unless you are qualified to do so. Refer all servicing to qualified service personnel.

Content

Caution.....	1
1. TECHNICAL SUPPORT.....	0
2. GENERAL DESCRIPTION.....	1
2.1 INTRODUCTION	1
2.2 FEATURES:.....	2
2.3 BLOCK DIAGRAM	2
2.3.1 ATC Loops.....	3
2.3.2 APC Loops.....	3
2.3.3 RF loops	3
2.3.4 Data Collection, Control and Internet.....	3
3. SPECIFICATION	4
4. BOARD ILLUSTRATION	5
4.1 FRONT PANEL	5
4.2 REAR PANEL	6
5. INSTALLING.....	7
6. TESTING.....	9
6.1 TEST EQUIPMENT CONNECTION FOR RESPONSE AND RETURN LOSS TESTING	9
7. TROUBLE SHOOTING	10
Trouble.....	10

1. Technical Support

Before you begin using the RF-T860, familiarize yourself with this user's manual.

If you need assistance while working with RF-T860, please contact us.

Please do not open the unit and verify any circuit yourself, and it is necessary to make some simple check before calling service.

When shipping equipment for repair, please follow below steps:

- Pack the unit security.
- Enclose a note describing the exact problem.

Ship the unit **prepaid** to us.

2. General Description

2.1 Introduction

RF-T860 is an intelligent high performance fiber Transmitter. It is widely used at node locations of a fiber optic link to convert the RF signal to optical signal in the HFC plant.

The capability of RF-T860 is:

- Laser power ON/OFF can be adjusted by the lock. While the Lock is at OFF position, the laser is cut off, the AC power still can be fed into the unit.
- LCD shows the working status, including eight working messages, working address, warning message. Press the Status Display Switch could select the showing of the status. When working status is abnormal, the message on the LCD flashes, the Status Display Switch is invalid, the RF circuit and laser power would be cut off automatically.
- Reset key is used to reset the working of the transmitter while the Applied power is on, which commonly be used in the start and the alarm status.
- Three Indicating LED show the status of the unit, including the Applied power, working status, RF level. Green lamp shows the status is normal, while red lamp shows the status is abnormal. These LED are monitored by the CPU.
- ALC/MGC switch. Set the ALC/MGC switch to “MGC” side before you adjust the RF attenuation. One RF Test Port is on the front panel. Measure the RF input level to find the optical modulation depth. User can obtain the accordant specification stipulate on this manual by adjusting the RF attenuation. Set the ALC/MGC switch to “ALC” side, none manual work is needed. Input the RF signal, the Unit adjust the Gain of the RF to maintain the RF Input Level and the general depth of the optical modulation index.
- RS232 port is installed for the monitor control of the CPU.



Figure 1. RF-T860

2.2 Features:

- Low Input RF Level
- ALC/MGC
- APC/ATC
- Pre-distortion circuit
- CPU monitor control the working statuses
- LCD shows the working status and the alarm message
- Cut off the optical power automatically when the work is abnormal
- RS232 port for the monitoring status through remote computer

2.3 Block Diagram

The transmitter is based on 6 functional blocks. Optical laser temperature controlled (ATC), Optical power control electronics(APC), Data Collection, Controller, Communication Circuit, RF Circuit, and so on.

The Block Diagram is in Figure 2.

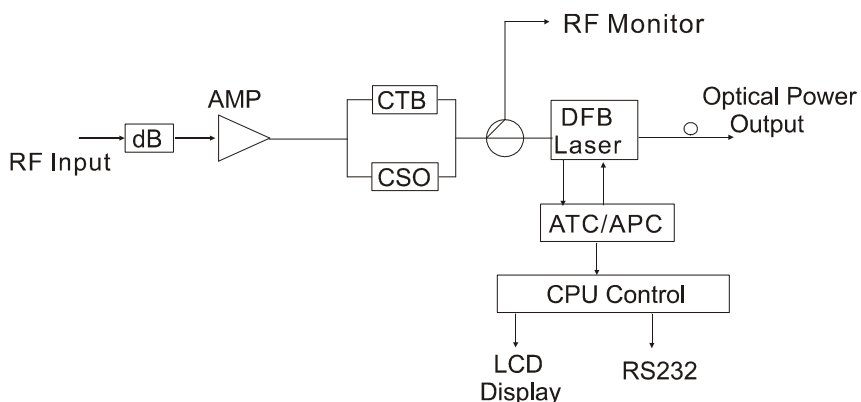

Figure2: RF-T860 Block Diagram

2.3.1 ATC Loops

There is one loop for operating the laser diode at constant optical output power, as well as at constant temperature, by means of an Auto Temperature Control Loops (ATC). The Optical Power and the life-span would be influenced by the temperature of the heat Optical Laser. The feasible temperature of the chip is 25°C. The semi conductor Laser is sealed in the parts, a temperature detector resistance is stored in this parts.

2.3.2 APC Loops

Due to the aging of the laser diode, the Optical power will drop down, the Carrier Noise will declined, on the same time the CSO, CTB would get bad. The Auto Power Control Loop is mandatory to maintain the stable of the optical power, to control the optical power of the laser automatically. One optical fiber detector circuit is sealed in the semi-conductor laser parts, which could supervise the laser diode.

In case of an optical output power failure, an alarm is generated on the front case LCD.

2.3.3 RF loops

The RF circuit is used for the amplify of the RF signal, ALC/MGC function, Pre-distortion of the RF signal.

- a) MGC Manual Gain Control.
- b) ALC Auto Level control.
- c) Pre-distortion circuit

2.3.4 Data Collection, Control and Internet

3. Specification

3.1 Optical Out put		
1) Optical Wavelength	1310±20nm	
2) Conversion Efficiency	>0.1mW/mA(6mW)	
	>0.2mW/mA(8-14mW)	
3) Optical Output Power	4 5 6 7 8 9 10 11 12 13 14 15 16 20 24mW	
4) Optical Fiber Type	Single Module (9/125μm)	
5) Fiber Connector Type	SC/APC or FC/APC	
3.2 RF Input		
1) Frequency Range	45-870MHz	
2) Frequency response	<±0.75dB	
3) Input Return Loss	>14 dB	
4) Input Impedance	75 Ω	
5) Attenuator Adjustment Range	10 dB	
6) Input Level Adjustment Range	75dBμV-80dBμV	
7) Connector Type	F	
3.3 Link Specification		
1) CNR	> 52 dB	@59 channel PAL B/G Carrier; -1dBm Optical power Receiving
2) CSO	< - 61dBc	
3) CTB	< - 65dBc	
3.4 LED and Alarm		
1) Power	Normal= Green	Abnormal= red
2) Working Status	Normal= Green	Abnormal= red
3) RF Status	Normal= Green	Abnormal= red
3.5 Circuit		
1) Operating Temperature	-10°C-50°C	

2) Storage Temperature	-15°C- +55°C
3.6 Power Supply	
1) Input Power Range	100V-260V
2) AC Power Frequency	50Hz
The machine should be safely grounded.	

4. Board Illustration

Front Panel

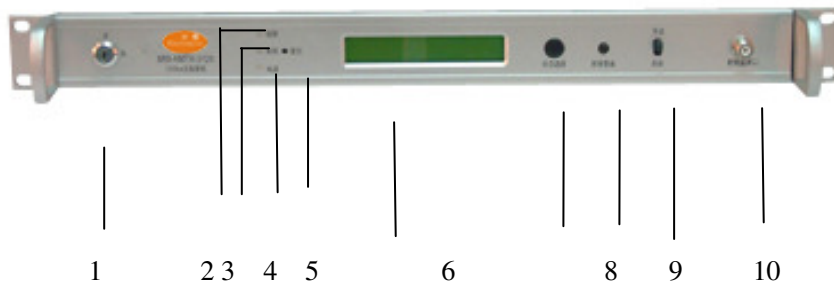

Figure 3. RF-T860 Front Panel

1. Laser Power ON/OFF Lock
2. Power Indicating Lamp
The Lamp lit green when the power is normal, or else, the lamp turn red, and the LCD shows warning message.
3. Working Indicating Lamp
The Lamp lit green when the working is normal, or else, the lamp turn red, and the LCD shows warning message.
4. RF working status Indicating Lamp
The Lamp lit green when RF Input signal is available, or else, the lamp turn red. The lamp lit red also when the laser power is off.
5. Reset Key
Press the key to reset the CPU. The LCD alarm message is caused by the

control of the software, Reset Key could resume the normal working status.

6. LCD

The LCD shows the status of laser temperature, cooler current, laser optical output power, laser bias, and switching power voltage when the transmitter's working status is normal, otherwise, the LCD shows the warning message.

7. Status Display Switch

The LCD shows the status of laser temperature, cooler current, laser optical output power, laser bias, and switching power voltage. Press this switch to select the other status on the LCD.

8. RF Attenuator

Adjust the RF attenuation with is switch.

9. ALC/MGC Switch

Set the "ALC/MGC "Switch to "MGC" side before you adjust the RF attenuation. Put the "ALC/MGC "Switch to "ALC" side to maintain the general RF input to the laser.

10. RF Test Port

RF Test Port is used for monitoring the inject RF Level. When the testing RF Level equals with the value offered by the supplier, users can obtain the accordant specification stipulated on this user's manual.

4.2 Rear Panel

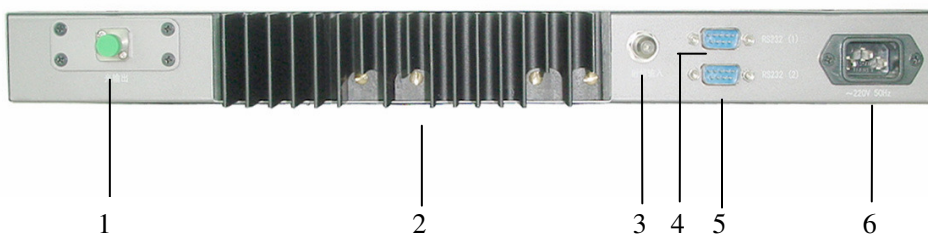

Figure 4. RF-T860 Rear Panel

1. FC/APC / SC/APC Mating Receptacle.

Optical signal Output Port. The adaptor is installed on a movable panel. It is easy for the changing and clearing the Optical Connector.

2. Heat Sink

To keep the temperature of the amplify module.

3. RF Input Port(F type)
4. RS232(1)
Preinstalled for the use of the CPU, convenient for monitor control.
5. RS232(2)
Preinstalled for the use of the CPU, convenient for monitor control.
6. AC power socket (220VAC 50Hz)
The Voltage range should be 100~250VAC.

5. Installing

Invisible optical beam comes out from the end of the optical connector, permanent damage would happen to eyes if see it directly.

1. Fiber connection
Power off, carefully remove the protective cap from the end of the FC/APC / SC/APC connector, insert the clean optical connector into the mating receptacle and tighten the connector securely.
2. Power
Turn the “power ON/OFF” Lock to ON position. Apply power to this transmitter, the Power Indicating Lamp lit green when the power is normal. Otherwise, cut off the power immediately(and so on in the abnormal power in the future), and contact with supplier.

This machine should be safely ground.

3. LCD display and lamp indication
LCD shows “PLEASE WAIT...”.
After a moment, shows “LASER TEMP 2× °C”(between 23 °C ~ 27 °C) and “COOL CUR ××× mA”.
Press the “Status Indicating” switch again, the LCD will show “OPT POWER ×× mW” and “BIAS CUR ×× mA”.
Press the “Status Indicating” switch again, the LCD will show “LOCAL ADDRESS××××××H”.
Press the “Status Indicating” switch again, the LCD will show “POWER ××.×V ×.×V ×.×V”.
Repeat the above steps for several times, if the specifications are almost the same, it means the transmitter is on normal working status.
4. The alarm lamp on the front panel is lit red first then turns green after the LCD shows message.

5. The “RF Level”(Refer to the RF input signal) lamp is lit red first and turns green when the RF input signal is applied.

6. Reset or resort to the supply

If the transmitter is not in proper order, the above three lamps are lit red, the LCD show alarm message and remind the user to turn off the machine, the software would reset automatically, otherwise, please press the RESET key to repeat step 3 above. **Important: If the machine still can not work after you press the RESET key for several times, please cut off the power and contact the supplier.**

7. Input RF Signal

When the transmitter is in normal working status, input RF signal and the “RF Level” Lamp will turn green.

8. MGC/AGC

Set the “ALC/MGC Switch” to “MGC” side and adjust the RF attenuator until the RF Test Port level equals the value listed in Table below: (the suggested monitoring frequency is 543.25MHz)

Also you can set the “ALC/MGC Switch” to “ALC” side and do not need any adjustment. (The RF Test Port Level should be maintained on 75-85dB μ V). Please note that in this case the laser input level $V_i = P \sqrt{N}$, P represents the level of one channel, N stands for the channel number. The supposed channel number of this transmitter is 59. If the channel number is below 59, the machine will automatically boosts the laser input level to maintain the same V_i , so the RF Test Port Level will increase, and the output level of the Optical Receiver in this system will also increase.

4.5 dBm Link Loss via per 10 kilometers

Address:	
RF Test Port Level	dB μ V
Laser Bias Current	mA
Optical Power	mW

6. Testing

6.1 Test Equipment connection for Response and Return Loss Testing

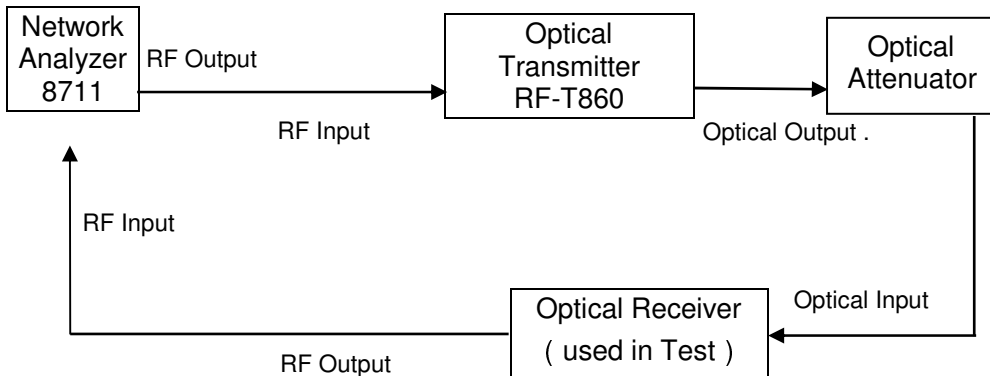

Figure 5 Test Link of Response and Return Loss

1. Referring the Figure 5 to connect the Test Equipment. Accurate the Network Analyzer.
2. Optical power had been factory reset. Use Attenuator to select corresponding attenuation, make sure the receiving power is 0dB(not above 3dB)
3. Connect optical transmitter and receiver with optical attenuator. Connect Network Analyzer with optical transmitter's RF input port. Connect Network Analyzer with optical receiver's RF input port.
4. In the Frequency Range 45M-750/860MHz , frequency response is within $\pm 0.75\text{dB}$, Return Loss is above 14dB .(Note: When ALC/AGC switch is at MGC side, adjust the RF attenuation with RF Attenuator. Be sure the Flatness is in $\pm 0.75\text{dB}$ from lowest loss to 10dB loss.)

7. Trouble shooting

Trouble	Reason.	Solution
Power on, the LCD is off.	Switch Power is abnormal.	Check the power socket, connect the supplier to get help.
Power on, alarm signal shows on the LCD.	<p>1.The Operating Temperature is too low, waiting for a moment.</p> <p>2.Waiting for a moment after power on.</p>	<p>The software would reset the automatically, otherwise, please press the RESET key.</p> <p>If the machine still can't work after you press the RESET key for several times, please cut off the power and contact the supplier.</p>
Power on, LCD shows normally, but Optical Power is abnormal	The optical connector is dirty.	Clean connector ends with a lint free tissue and alcohol (above 99%) before mating. Loose screws fixing the optical connector plate to clean the connector when it is necessary.